



CONÓCEME MÁS

SOY LA

CR4
125

**ESTOS SON
LOS BENEFICIOS**

QUE TENGO PARA TÍ



CR4 125



SISTEMA ANTIBLOQUEO DE FRENS



SISTEMA DE ENCENDIDO AUTOMÁTICO DE LUCES (AHO)



MAYOR CALIDAD Y RESPALDO



MOVILIDAD PARA TI Y TU FAMILIA

MÁS INGRESOS

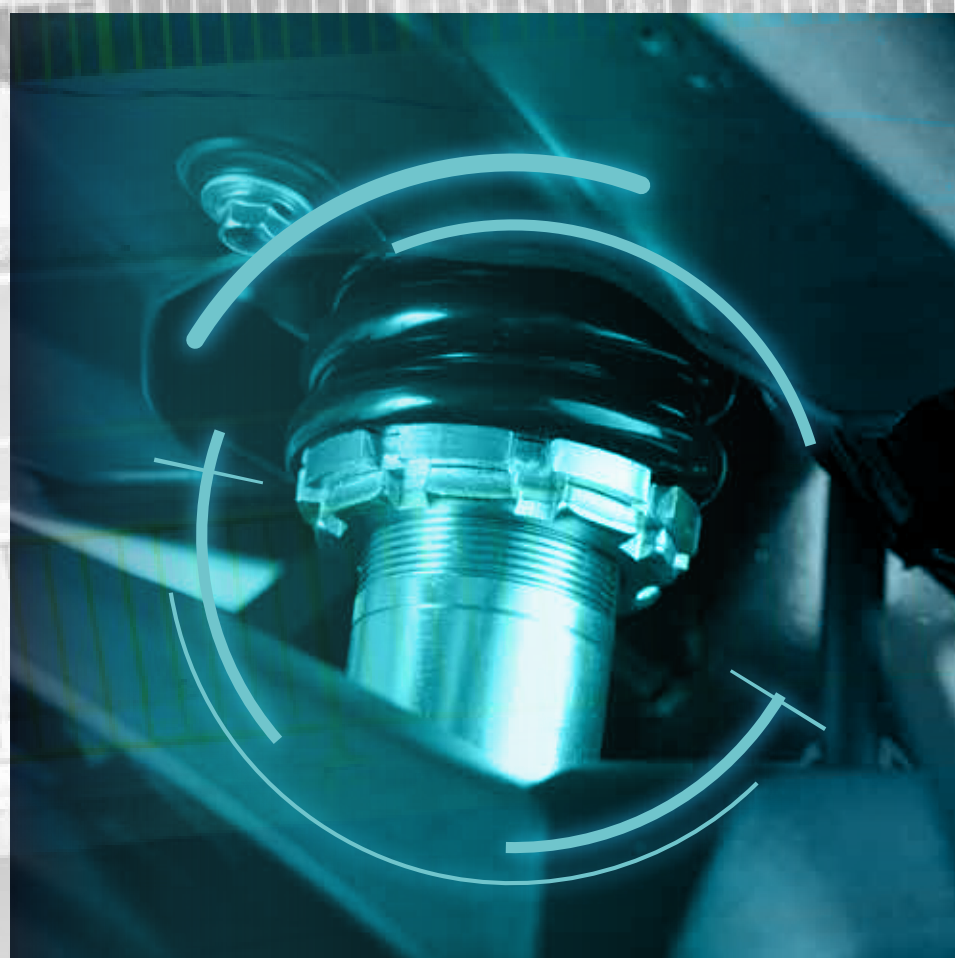

SUSPENSIÓN TRASERA

UNI SHOCK

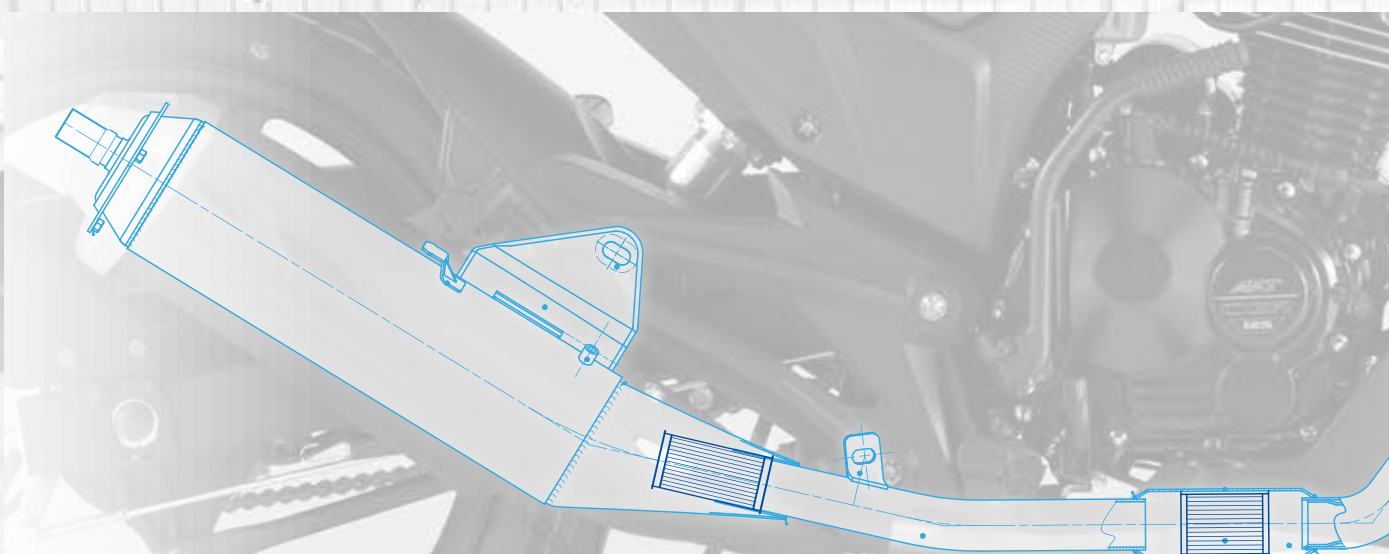

TECNOLOGÍA **EURO 3**



▶ **AHORA CON**



**VELOCÍMETRO
ANÁLOGO / DIGITAL**

**FRENO DE
DISCO DELANTERO**



FICHA TÉCNICA

MOTOR
CILINDRAJE
POTENCIA
TORQUE MAX
COMPRESIÓN
ARRANQUE
SUSPENSIÓN DELANTERA
SUSPENSIÓN TRASERA
FRENO DELANTERO
FRENO TRASERO
LARGO X ANCHO X ALTO (MM)
ENCENDIDO
DISTANCIA ENTRE EJES (MM)
DISTANCIA DEL MOTOR AL PISO (MM)
LLANTA DELANTERA
LLANTA TRASERA
PESO SECO
CAPACIDAD DEL TANQUE
GARANTÍA
REVISIONES GRATUITAS

**CGR 4T OHV
125 C.C.
10HP (7.5KW) @ 8000 RPM
9.2 NM @ 8000 RPM
9.5:1
ELÉCTRICO Y A PATADA
TELESCÓPICA HIDRÁULICA
UNISHOCK
DISCO
TAMBOR
1990 X 780 X 1030
CDI
1300
170
80/90 X 17
110/80 X17
118 KG
3.46 GL
20 MESES O 20.000 KILÓMETROS
5**

DESDE \$ 4.490.000



COLORES



Síguenos



WWW.AKTMOTOS.COM

